

Today

Finish Chapter 22 (Electrostatics)
Then Chapter 23 (Electrical Circuits)

Looking ahead:

➤ **Next Lecture Tue Apr 17:** Finish Ch 23, followed by Review Session

➤ **Friday Apr 20: Midterm 2**

(Chs: 11, 13, 14, 15, 19, 20, 22, 23)

!! Do some study over spring break !!

Chapter 23: Electric Current

Electric Current

- Is the **flow of electric charge** (i.e. charged particles, usually electrons) between regions of different electric potential.
- When there is no potential difference, there is no charge flow, no current.
- Consider high potential object, eg van de Graaff dome. Connect to earth with wire – charge flows down to the lower potential of the ground. But this current is brief, because it stops once dome reaches the same potential as the ground.
- In order to get a *sustained* current flow, need some kind of pump (i.e. battery)

• Before getting into this, consider fluid analogy:

Water flows from high pressure to low pressure, but stops flowing once pressures (heights) are equal.

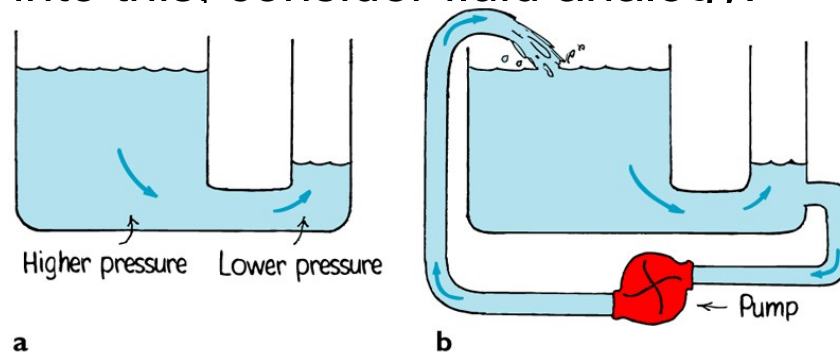

← Can get sustained water flow if pressure difference maintained via a pump

Electric current cont.

- What actually is flowing? Depends on the circuit:
 - In circuits of metal wires, its electrons (called *conduction electrons*), free to move (whereas positive ions are fixed in a lattice).
 - In car batteries, it's positive ions in a fluid (sulfuric acid and distilled water mix)
- Rate of flow measured in **amperes** – amount of charge passing a given point per second:
 - 1 ampere = 1 Coulomb/sec
- Note that we often call “potential difference” simply “voltage” : need a voltage across two points in order to get a current between them.
Recall from Ch. 22, that the unit is volt.
- Usually, symbol for current is I (but not used in your book)

Question

In a circuit carrying a 1-ampere current, how many electrons pass a given point in a second?

1 Ampere means 1 Coulomb per second, and recall that 1 C is 6.25×10^{18} electrons (i.e. 6.25 billion billion electrons.)

Clicker Question

Is there a net charge on a current-carrying wire?

- A) Yes
- B) No

Answer: B

No (not usually). The negative conduction electrons flow through the atomic lattice made of positively charged nuclei. The atoms were originally neutral, so the # electrons = # protons.

Voltage sources

- Recall, need an “electrical pump” for sustained current flow, to maintain a potential difference. Called a “voltage source”: eg chemical battery, or generator

- Batteries do work to pull negative charges away from positive ones.

E.g. In chemical battery, a chemical reaction between zinc or lead in acid releases chemical energy in broken bonds – this energy is converted to electric potential energy.

E.g. Generators use electromagnetic induction (see later in Ch 25) to separate charges.

- This work is stored in the battery, and is available at the battery terminals. We characterize batteries by their “voltage” = “electrical pressure” (eg car battery is 12-V)

- Note terminology: **Voltage** across a circuit vs **current** through circuit

c.f. fluids **Pressure difference** across a pipe vs **water flow** through pipe

Electrical Resistance

- How much current there is depends on what's in the circuit as well as the voltage. i.e on the **electrical resistance**

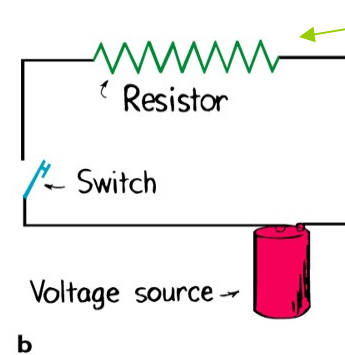
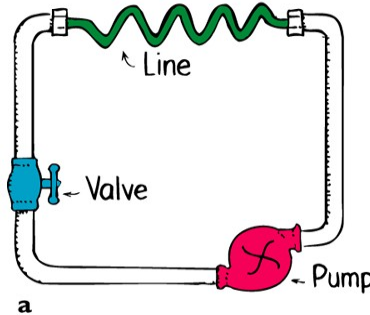

Circuit symbol is a zig-zag, can represent lamp, heater etc...

Copyright © 2006 Paul G. Hewitt, printed courtesy of Pearson Education Inc., publishing as Addison Wesley.

- c.f. fluids – eg a short and wide pipe has less resistance than a long and skinny one. Similarly with wires:
- Electrical resistance (symbol R), measured in **ohms**, Ω , and depends on:
 - length** (longer, more resistance)
 - thickness** (thinner, more resistance)
 - conductivity** (property of type of metal, eg steel more than copper)
 - temperature** (hotter, more resistance usually)

Ohm's Law

Relationship between current, voltage and resistance in a circuit:

$$\text{Current} = \frac{\text{voltage}}{\text{resistance}}$$

In units, amperes = $\frac{\text{volts}}{\text{ohms}}$

Note that this is often written as $V = IR$

current
voltage
resistance

So, devices with less resistance draw more current from a given potential difference.

Questions

(1) A typical lamp cord has a resistance of 1Ω while a typical light bulb has resistance of 150Ω . If both are connected to a 120-V circuit, how much current is drawn?

$$\begin{aligned}\text{Current} &= \text{Voltage}/\text{Resistance} \\ &= 120 / (1 + 150) \\ &= \underline{0.79 \text{ Amperes}}\end{aligned}$$

(2) What is the resistance of an electric frying pan that draws 3 A from the same 120-V source? First, do you expect the resistance to be greater or less than in (1)?

Since it draws more current, expect its resistance to be less:

$$\begin{aligned}\text{Resistance} &= \text{Voltage}/\text{Current} \\ &= 120\text{-V} / 3\text{-A} \\ &= \underline{40 \Omega}\end{aligned}$$

Electric Shock

- Electric shock is caused by large *currents* through the body. Since current = voltage/resistance, this also means large voltages cause shock.

But it depends on body's resistance:

If soaked with salt water, resistance can be as low as $\sim 100 \Omega$

If skin very dry, resistance can be up to $\sim 500\,000 \Omega$

Question: Why do we feel a tingle, when touching electrodes of a 12-V battery with moist skin, completing the circuit from one hand to the other, but we don't feel anything when our fingers are dry?

Because resistance is much less ($\sim 1000 \Omega$) when fingers moist, so the current that flows is detectable, whereas with dry fingers the current is so small that we don't feel it.

- So what currents can we feel? $0.001 \text{ A} - 0.005 \text{ A} - 0.01 \text{ A} - 0.015 \text{ A} - 0.07 \text{ A}$
can be felt painful involuntary loss of fatal if
muscle muscle through
contractions control heart > 1s
- Electric shock overheats body tissues, disrupts nerve function, upset electrical patterns in heart etc.

Electric shock cont.

- The huge decrease in resistance when you are wet is the cause of many fatal electric shocks λ

E.g. If touch a faulty 120-V light fixture, while touching ground, your body is a conducting path with 120-V potential difference across it.

If you are in the bath (which is connected to ground via plumbing), and say your resistance is 1000Ω , then current through you = $120/1000 = 0.12 \text{ A}$ – fatal.

(Never touch electrical devices while in the bath!) Also drops of water around switches can conduct current to the user.

- Note that distilled water is an insulator: but regular water is conducting because of ions (eg salts) dissolved in it. Also sweat is conducting.
- Note that need a *difference* in electric potential between two points in your body in order to feel the shock.

E.g. Bird here doesn't feel shock on electric wire of high voltage since all the bird is at the same high potential. But if he somehow put a foot on the ground, or on another wire of different potential, he'd be zapped...



Clicker Question

When a power line falls near you, to move away should you

- A) Walk away from it?
- B) Hop with both feet together?
- C) Get down on your hands and knees and crawl away?

Answer: B

Hop with both feet together! There may be a voltage difference across the ground, so if one foot is at a voltage much different from the other, you could get electrocuted.

Three-pronged plugs:

Important especially for appliances with a metal casing – the casing is connected directly to “ground”.

Electricity flows from “live”, through your appliance, back to neutral.

BUT if there is a loose wire in the appliance, it could contact the metal casing, raising its potential, and if you touch it, you’d get a possibly fatal shock. Instead, the ground wire ensures the casing is always at zero potential.

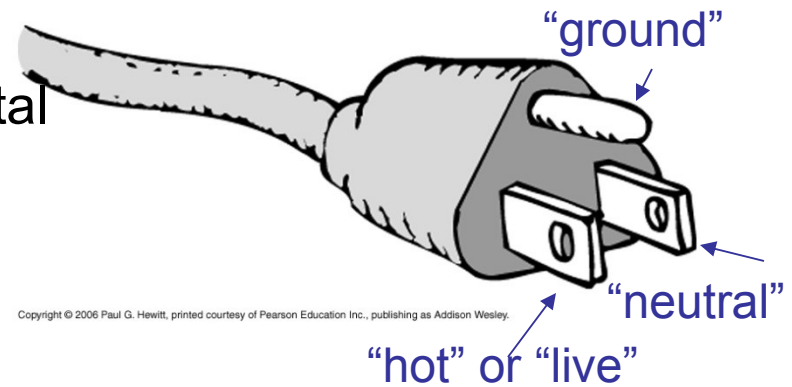

Question:

The third prong on electric plugs is longer than the pair of flat prongs. Why?

If longer, it will be connected first when plugged into a socket, so establishes the ground connection slightly before the appliance is electrically connected. This path to ground prevents harm to user if there is a short circuit in the appliance that would otherwise include the used as a path to ground.

Direct Current and Alternating Current

- Direct Current (dc): electrons flow in one direction only.

Eg. Battery, since terminals always have the same sign. Electrons flow from – terminal to +, and continue through circuit.

- Alternating Current (ac): electrons go first in one dir, then in the opposite, then back again etc... alternating...

Eg. Household current.

Generators at 60 Hz (in the US) i.e. alternates back and forth at freq of 60 cycles per second. See later (Ch 25) why more useful.

- Voltage of ac in US is 120-V (for those who know what it means, this is rms value. Don't worry about it otherwise).

Europe uses 220-V since power transmission is more efficient at higher voltages (but US didn't change since much equipment was designed for the lower 120-V)

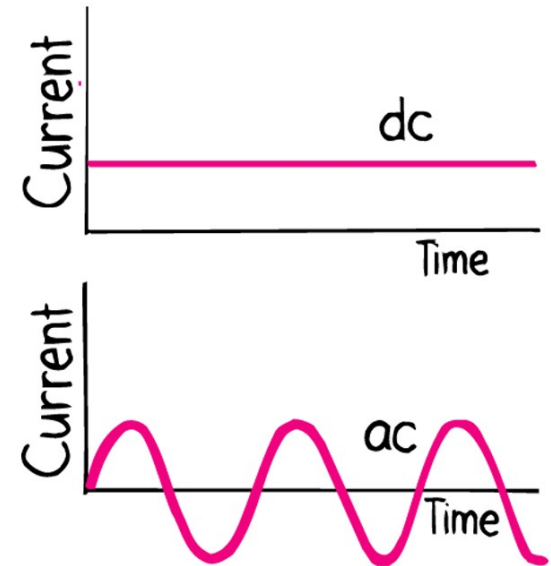

Copyright © 2006 Paul G. Hewitt, printed courtesy of Pearson Education Inc., publishing as Addison Wesley.

i.e. non-examinable

Extra reading: Converting from ac to dc

- Although household current is ac, sometimes want to run dc devices, using an ac-dc convertor.
- Need a **diode** – like a one-way valve:



Copyright © 2006 Paul G. Hewitt, printed courtesy of Pearson Education Inc., publishing as Addison Wesley.

Input is ac

Diode only lets + current pass. Pulsed.

- How to smooth out flow and get rid of zero current regions?

Use a **capacitor**: recall this stores charge, and that takes time, so introduces retarding effect, leading to smoother output current.



Copyright © 2006 Paul G. Hewitt, printed courtesy of Pearson Education Inc., publishing as Addison Wesley.

Here a capacitor is used to smooth out flow

Using a pair of diodes reverses polarity of – part instead of eliminating them.

Speed of electrons in a circuit.

- When we flip a light switch, the light comes on almost immediately (ac or dc). In fact the electrical *signal* travels at nearly the speed of light, $c = 3 \times 10^8$ m/s.
- But it is NOT the electrons that travel so quickly.
- First, how are the electrons moving? Consider first dc.

Distinguish **random fast motion** (\sim million m/s) with **slower drift velocity** (~ 0.0001 m/s)

No net current – just random thermal motion in all directions

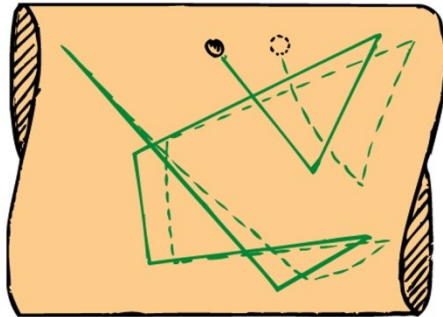

Copyright © 2006 Paul G. Hewitt, printed courtesy of Pearson Education Inc., publishing as Addison Wesley

A battery or generator sets up an electric field, so while they are buzzing around randomly, they are also being nudged in a fixed direction by field. Collisions with atoms prevent them from gaining much speed from the field - net effect is a slow drift velocity in field direction.

- It takes 3 hours for an electron to travel through 1 meter of wire!
Slower than a snail...

- Although an electric signal travels at nearly speed of light, the electrons themselves move in response to this at a much slower speed
- In fact, in an AC circuit, conduction electrons don't progress along wire – instead, they oscillate about fixed positions. It's the *pattern* of motion that is carried across the circuit at speed of light.
- It is *not* the bumping of electrons into each other that propagates the electricity:

(ANTI-)DEMO: Let's pretend we are electrons! Line people up standing close to each other. Person on the end gives a shove to neighbor, who as a result shoves his neighbor ...etc down the line till the person at the other end is shoved forward. This is NOT a model for how electric current travels! (It is more a model of how *sound* travels). It's too slow.

Rather, signal for person-at-far-end to move arrives much quicker – it's as if a green-light signal went off at the other end. Every person (electron) reacts almost simultaneously. So signal is almost instantaneous...

When you turn on your key to start your car, electrons migrate from the negative battery terminal through the electric network to the starter motor and back to the positive battery terminal. About how long is required for one of the electrons to leave the negative terminal and go through the circuit and back again? Less than a millisecond? Less than a second? A few seconds? Or about a day?

Answer: Actually about a day!

The “source” of electrons in a circuit

- Source of electrons is the conducting circuit itself.
- Electrons are *not* stored in an outlet, to be released when an appliance is connected.
- The outlets in homes are ac, so actually electrons make no migration through a wire. But even in dc circuits, the battery is not the source of the electrons, rather it is the source of *energy* that makes the electrons in the circuit move.
- *Power utilities sell energy, not electrons.*
- Energy is carried by electric field. Eg. If put 120-V across a lamp, each Coulomb of charge dissipates 120-Joules of energy. Most is heat, some is light.

Electric Power

- Current expends energy in a circuit – mostly as heat, but also for what it's used for eg turning a motor, light.
- Recall $\text{Power} = (\text{work done})/\text{time} = (\text{energy})/\text{time}$. For electrical circuits,

Power = current x voltage

In units: Watts = amperes x volts

Cost of electricity depends on power consumption over time

i.e. energy = power x time = often measured in kilowatt-hour (kWh)

E.g. A lightbulb rated at 120-W connected on a 120-V line, draws a current of 1A, whereas a 60-W bulb draws $\frac{1}{2}$ A.

Running the 60-W bulb for the same time as the 120-W one costs half as much.

Brightness depends on power

E.g. A toaster draws much more current than a lightbulb, so is much more expensive to use across the same household 120-V supply, if on for same time

Question

A toaster has a resistance of 60Ω . When connected across the household 120-V supply,

- a) how much current is drawn?
- b) how much power is delivered?
- c) how much energy is used if it is run for 1 minute?

$$\text{a) current} = \text{voltage/resistance} = 120/60 = 2 \text{ A}$$

$$\text{b) power} = \text{voltage} \times \text{current} = 120 \times 2 = 240 \text{ W}$$

$$\text{c) energy} = \text{power} \times \text{time} = 240 \text{ W} \times 60\text{s} = 14.4 \text{ kJ}$$

Electric circuits

- Circuit = any path along which electrons can flow.
- An electric **switch** is something that provides a gap in the circuit when opened, so stops the current and energy flow.
- Charge does not pile up anywhere; rather, it flows.
- A given circuit may have many devices. Can be connected in series or in parallel.

Series circuits

Single pathway for current between terminals of battery/generator.

Eg:

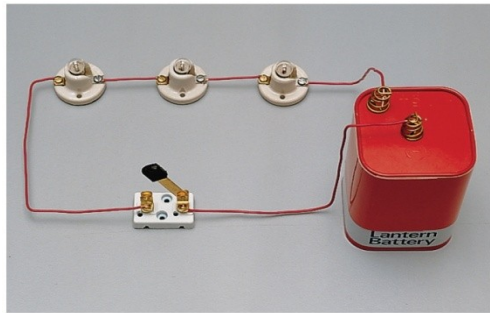

Copyright © 2008 Paul G. Hewitt, printed courtesy of Pearson Education Inc., publishing as Addison Wesley.

circuit
diagram

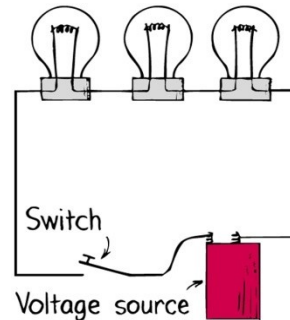
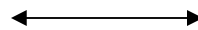

Copyright © 2008 Paul G. Hewitt, printed courtesy of Pearson Education Inc., publishing as Addison Wesley.

- Almost immediately after switch is closed, *same current* exists in all three lamps.
- Electrons in *all* parts of the circuit move at once.
- Break in circuit – means “open circuit” – no more current in any part of circuit eg if one lamp burns out.

Series circuits –some rules:

- Current through each device is the same (since single pathway for charge)
- Total resistance of circuit = sum of resistances of devices
- Current = (voltage of source)/(Total resistance), from Ohm's law
- Voltage drop across each device is proportional to its resistance.

This is also from Ohm's law, since voltage = current x resistance, and current is same for each.

- Sum of voltage drops across each device = total voltage of source.

This is also from Ohm's law. Also can interpret in terms of energy: amount of energy used to move each charge through entire circuit = sum of energies used to move that charge through each device in turn.

- **Main disadvantage** – if one device fails, current throughout circuit goes out.
 - Parallel circuits (see next) gets around this.

Parallel circuits

Wires form branches – separate paths for current.

Eg:

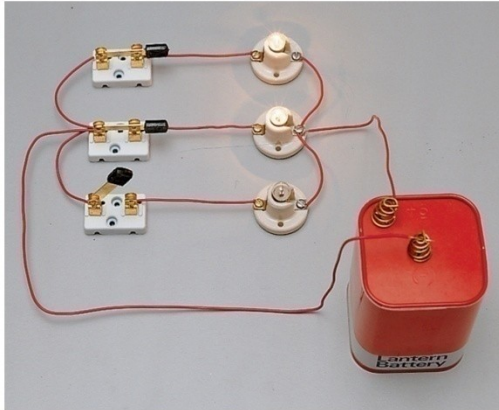

Copyright © 2006 Paul G. Hewitt, printed courtesy of Pearson Education Inc., publishing as Addison Wesley.

Circuit diagram
←→

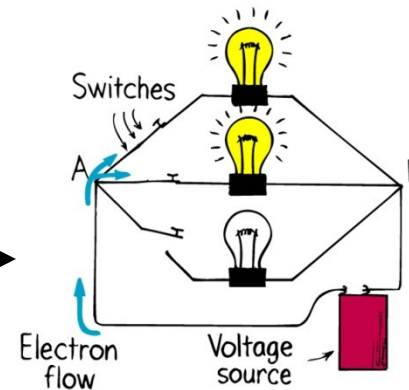

Copyright © 2006 Paul G. Hewitt, printed courtesy of Pearson Education Inc., publishing as Addison Wesley.

So, even if one lamp fails, the other two can still light up.

Even if only one lamp is lit, there is a complete pathway between battery terminals

Eg. modern Christmas tree lights, car headlights...

Parallel circuits – some rules:

- Voltage drop across each device is same. (Since each connects same two points A and B of circuit)

- Total current = sum of currents in each branch

- Current in each device (i.e. in each branch) $\sim V / R$ (resistance of branch)

Follows from Ohm's law applied to each branch, with same V across each.

- Circuits with more parallel branches have *less* overall (total) resistance.

A way to understand this – the effective “width” of the wire gets larger as you add a branch, so effective resistance is decreased.

Clicker Question

Consider two lamps connected first in series and then in parallel, across the same voltage source. If one burns out, what happens to the brightness of the other one when in series? How about when in parallel?

- A) In both cases, the other bulb goes out.
- B) In both cases, the other bulb is unaffected
- C) In series, the other bulb goes out; In parallel, the other bulb stays lit, same brightness.
- D) In series, the other bulb stays lit the same; In parallel, the other bulb goes out.
- E) In series, the other bulb goes out; In parallel, the other bulb gets brighter.
- F) None of the above

Answer: C

Series: the other goes out since no current can flow

Parallel: the other is unaffected – same voltage drop imposed across it and same resistance, so same current.

Another Question

If now a third lamp is added in series, to the series circuit, what happens to individual brightness of each lamp? How about adding a third in parallel to the parallel circuit?

Series: Each lamp dims, since overall resistance of circuit increases, so less current through each. (And less individual voltage drop as total voltage drop is shared by three instead of two).

Parallel: Unchanged. Still same voltage across individuals.

Parallel Circuits and Overloading

- Electricity enters home by two wires called *lines*, which then branch into parallel circuits connecting wall outlets, ceiling lights – so these have same voltage put across them (120-V)

- As more devices are plugged in, overall resistance of circuit in home decreases, and draws more current. (c.f picture)

- Sum of the currents in the branches = line current, so this can get too large to be safe, if too many devices plugged in. Circuit is *overloaded*, overheated, may start fire.

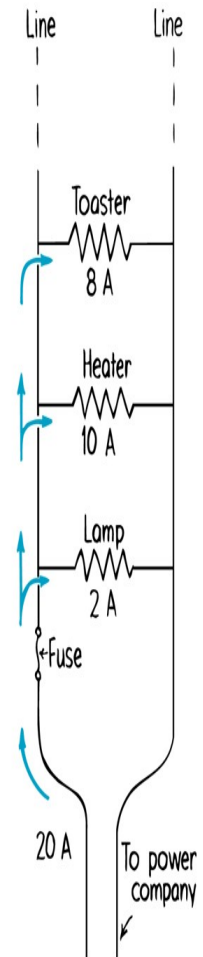

Parallel Circuits and Overloading cont.

Safety Fuses:

- Prevent overloading.
- Connected in series along supply line – so all current must pass through.
- Designed to melt at given current, so breaks circuit if current exceeds that (eg 20 A).
- **Circuit breakers** – used instead in modern buildings. Magnets or bimetallic strips that open a switch if current is too great.

Clicker Question

When the series circuit shown to the right is connected, Bulb A is brighter than Bulb B. If the positions of the bulbs were reversed,

1. bulb A would again be brighter.
2. bulb B would be brighter.
3. either of the above could occur.

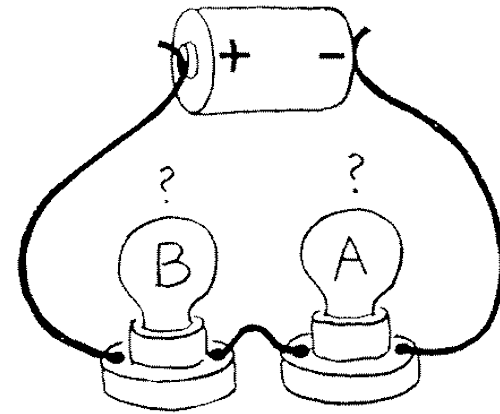
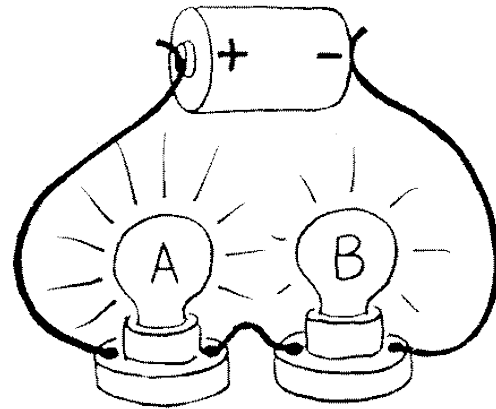

When the series circuit shown to the right is connected, Bulb A is brighter than Bulb B. If the positions of the bulbs were reversed,

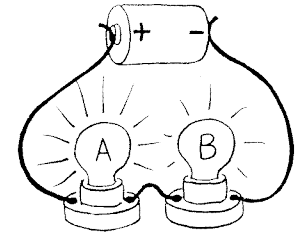

- ✓ **1. bulb A would again be brighter.**
- 2. bulb B would be brighter.
- 3. either of the above could occur.

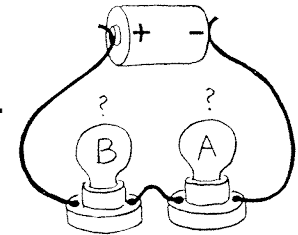

Answer: 1

The bulbs are connected in series, so the same current passes through both of them. Different brightness indicates different filament resistance. Bulb A is NOT brighter because it is “first in line” for current from the battery! After all, electrons deliver the energy, and they flow from negative to positive—in the opposite direction!