

6. Wheatstone Bridge Circuit

Introduction

There are some arrangements of resistors in circuits that cannot be reduced to simpler circuits using simple series and parallel combination rules. Complete analysis of such circuits requires Kirchoff's rules. Sometimes, as we will now see, under special circumstance some useful information about the circuit can none-the-less be obtained.

The Wheatstone Bridge Circuit

An example of a circuit that cannot be reduced using simple series and parallel rules appears

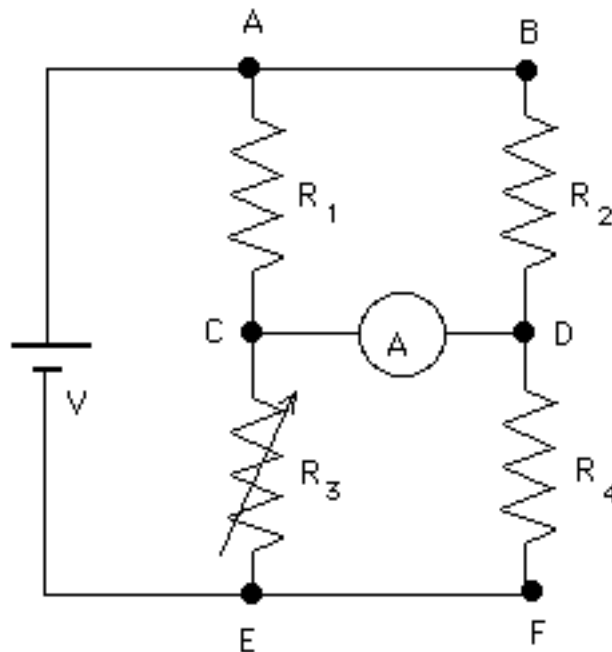

The Wheatstone bridge circuit above is usually operated by adjusting the variable resistor R_3 until **no current flows in the ammeter**. Under this special circumstance, the above circuit problem may be solved easily without the need for Kirchoff's rules. Notice that resistors R_3 and R_2 are NOT in parallel (because there is a different voltage across each resistor) if there is a current in the ammeter. Also R_3

and R_4 are NOT in series (because there is a different current through each resistor) if there is a current in the ammeter.

Originally the Wheatstone bridge was developed as a sort of "electrical balance" to measure unknown resistors placed in the position of R_4 and the adjustable resistor R_3 had a sort of scale which could be used to determine the value of the unknown resistor R_4 in a way we now describe. This original use of the Wheatstone bridge has been replaced with the digital volt, amp, ohmmeter in your circuit kit.

Analysis of the Circuit

Since no current flows in the ammeter, the electrical potential of point C is the same as the electrical potential of point D (otherwise current would flow between the two points).

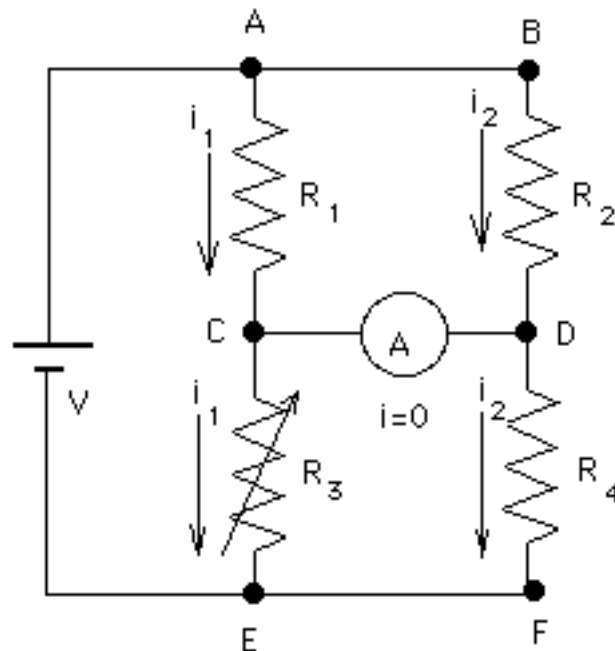

Since no current flows through the ammeter, the current i_1 through resistor R_1 is the same as the current through resistor R_3 as indicated in the diagram above. Similarly, the current i_2 through resistor R_2 is the same as the current through resistor R_4 .

It also follows (from the fact that points C and D have the same electrical potential) that the voltage drop across resistor R_1 is the same as the voltage drop across resistor R_2 so

$$i_1 R_1 = i_2 R_2 \quad (1)$$

Similarly, the voltage drop across resistor R_3 is the same as the voltage drop across resistor R_4 so

$$i_1 R_3 = i_2 R_4 \quad (2)$$

If you divide equation (1) by equation (2) the currents cancel out and one obtains

$$\frac{R_1}{R_3} = \frac{R_2}{R_4} \quad (3)$$

You can use equation (3) by solving for the unknown resistor R_4 obtaining

$$R_4 = \frac{R_2}{R_1} R_3 \quad (4)$$

Laboratory Exercise

PART A: Pick three different fixed resistors in the 10 k Ω range and combine with a 5 k Ω variable resistor (rheostat or potentiometer) and build a Wheatstone bridge circuit on your circuit board. Use the 12 volt lab power supply. Attach the ammeter and adjust the potentiometer until the ammeter reads zero current. Determine the value of the resistance R_3 of the potentiometer using your Ohmmeter. (Make sure you remove the power supply before making this measurement.)

PART B: Use equation (4) to obtain the value of the unknown resistance R_4 using the value for the variable resistor, R_3 you obtained in PART A. Does the value you obtain for R_4 using equation (4) agree with the value you obtained from the color code on R_4 ?